

Schnitt A-A

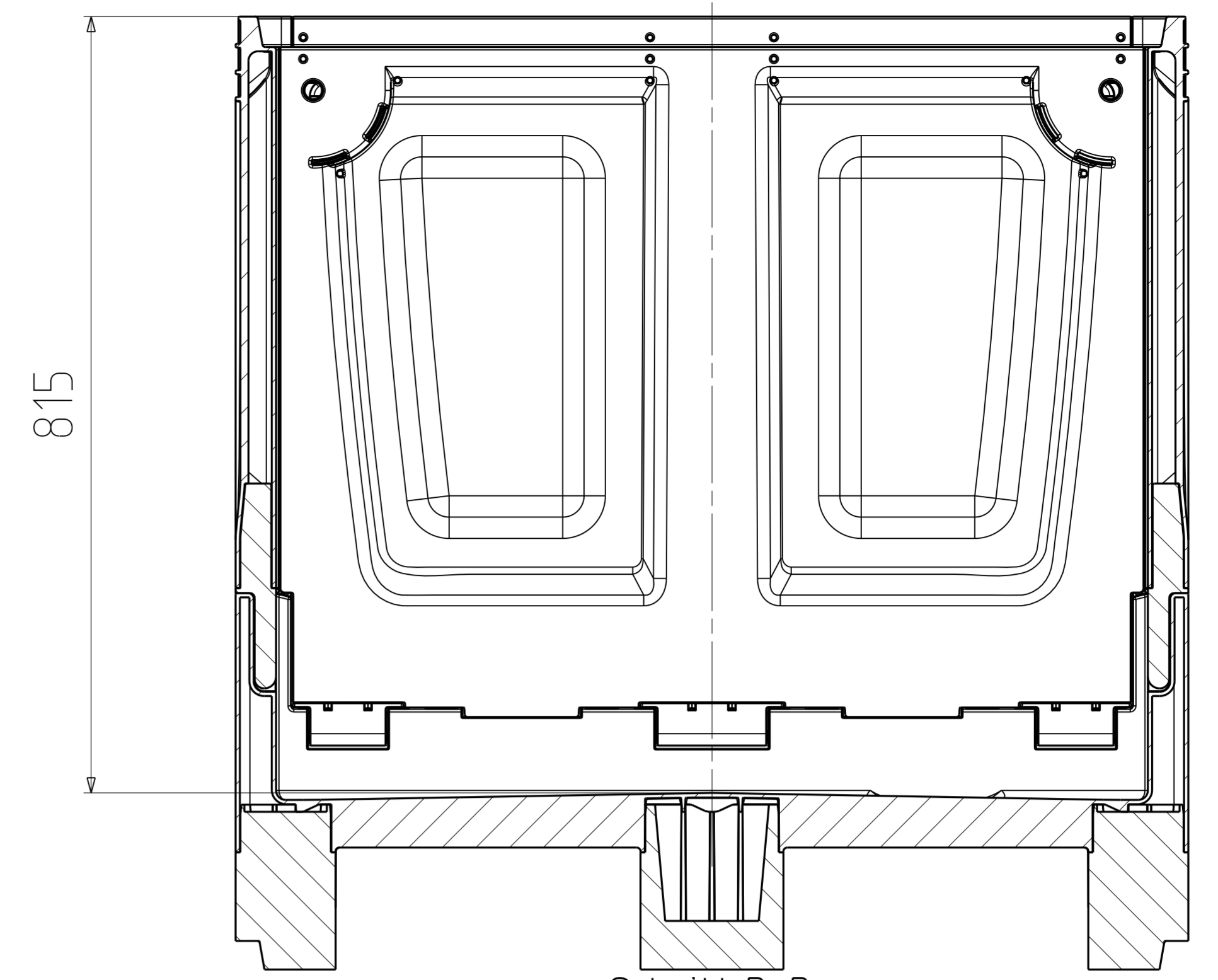

Schnitt B-B

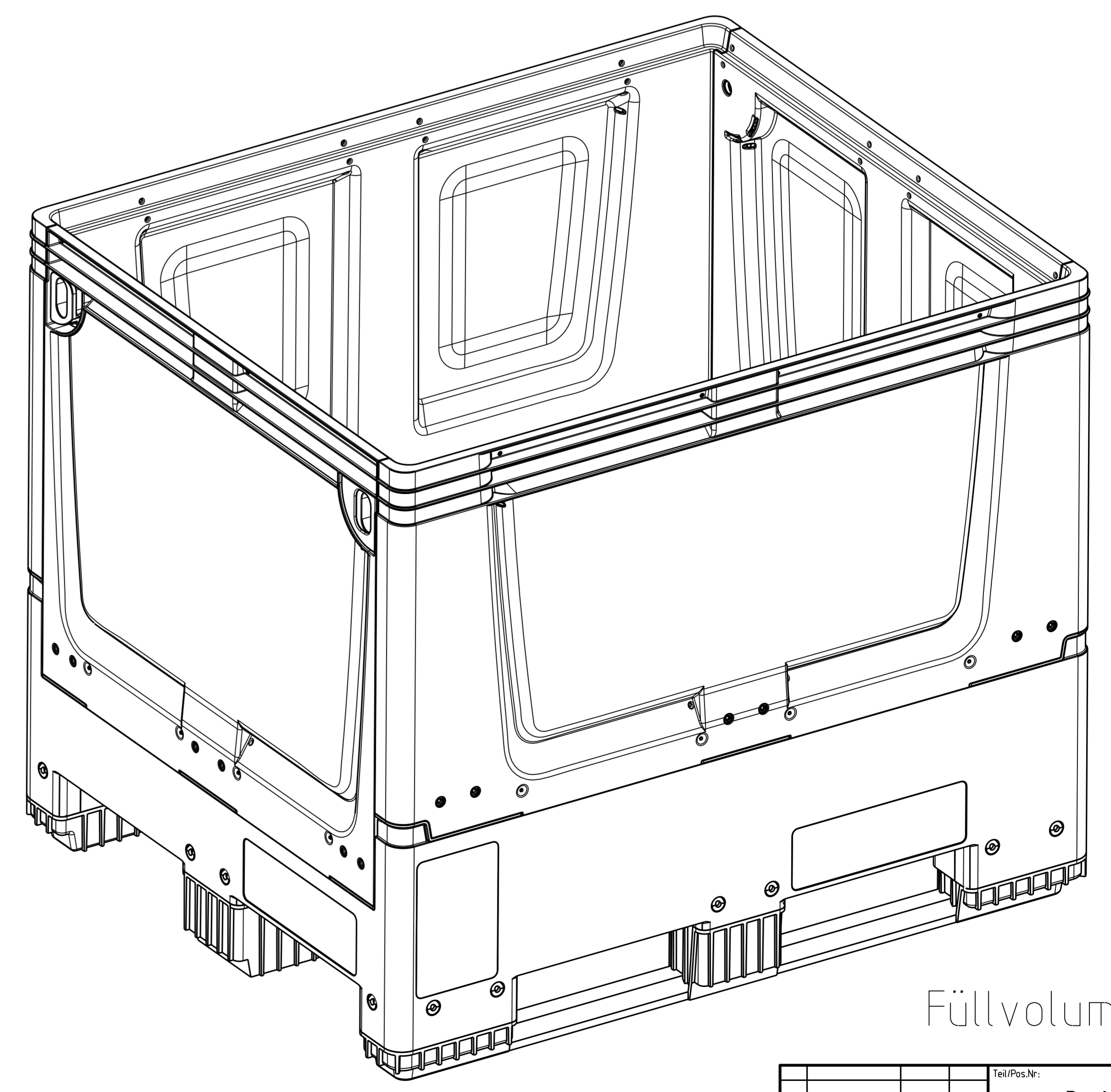
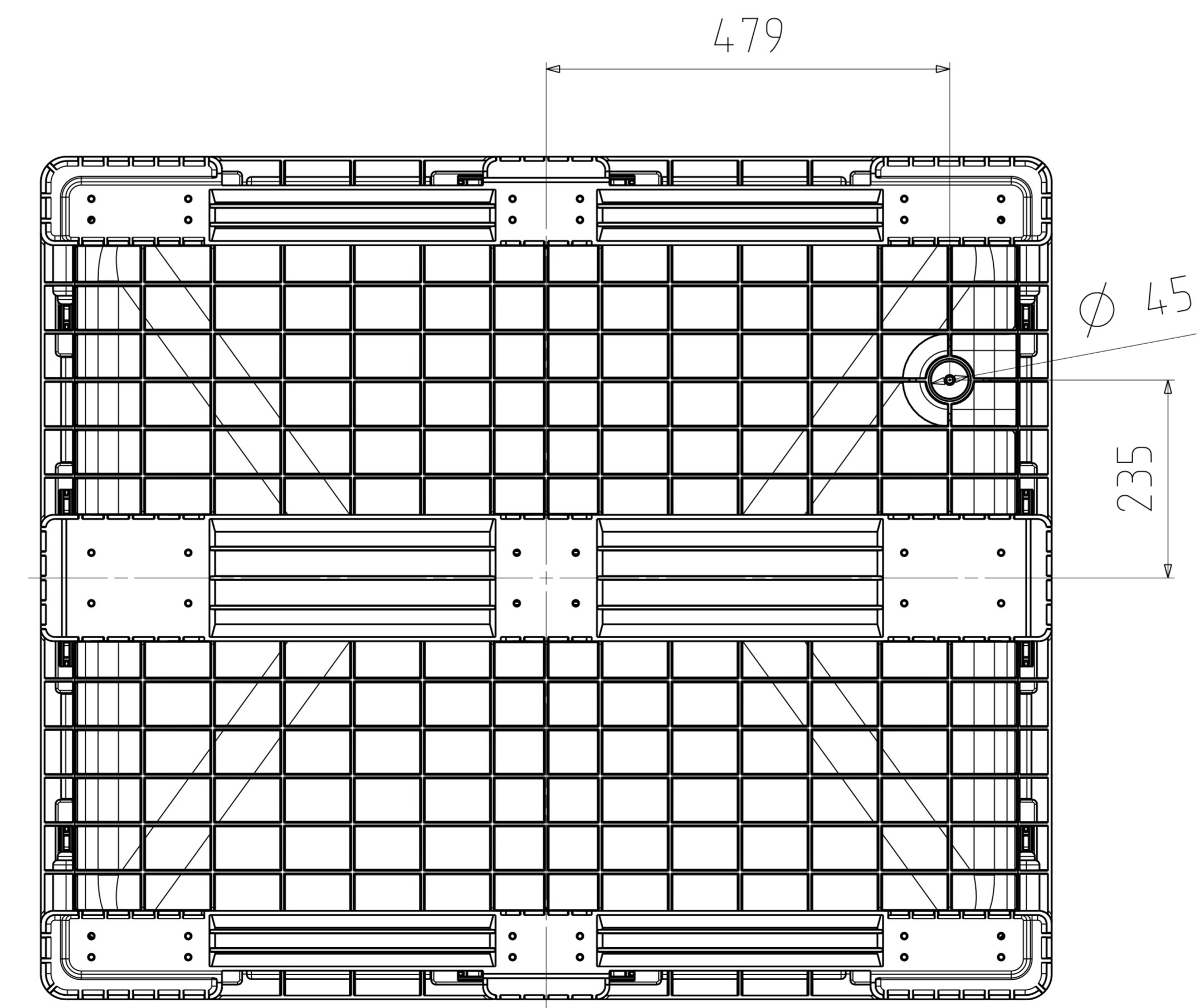
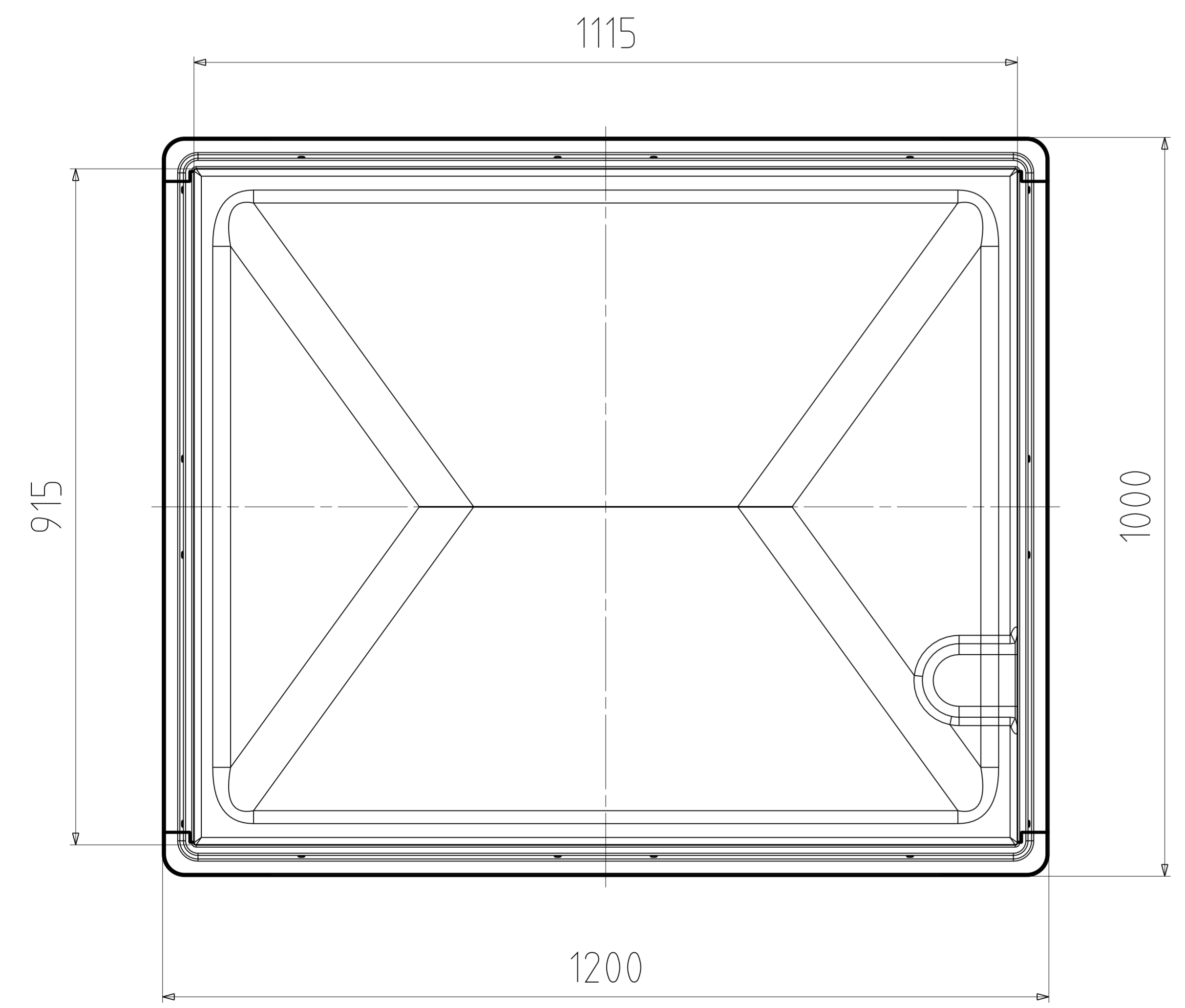
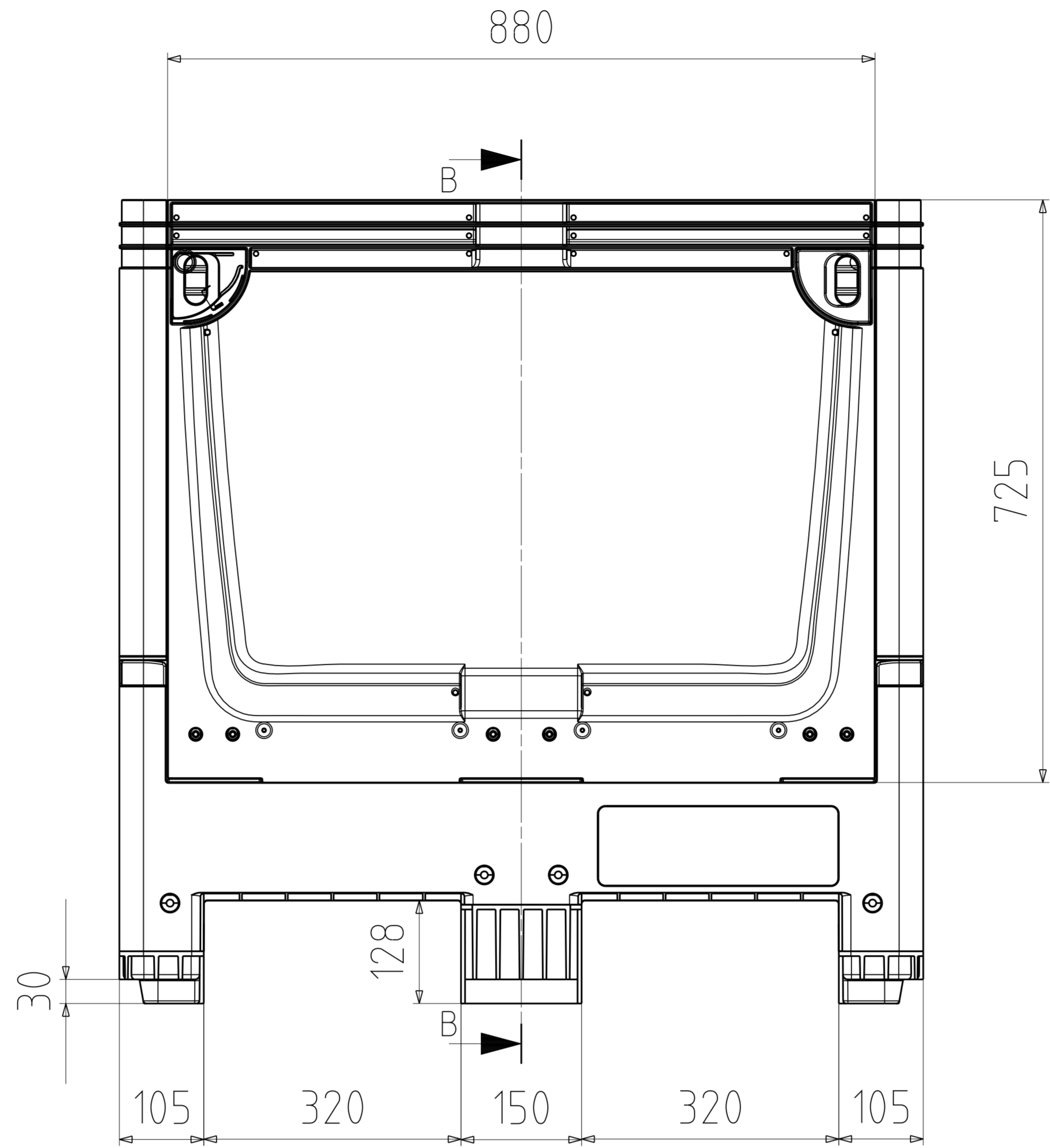
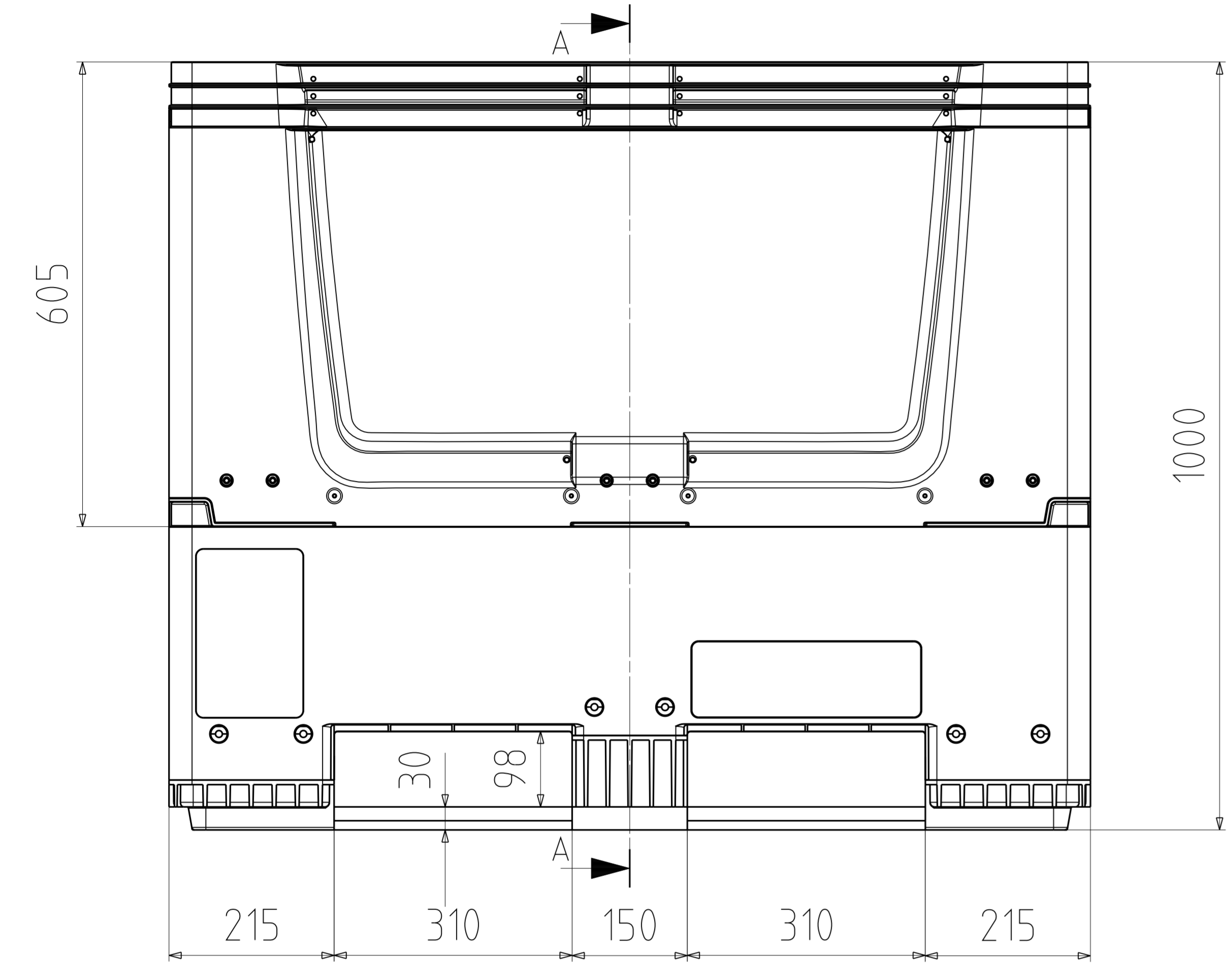
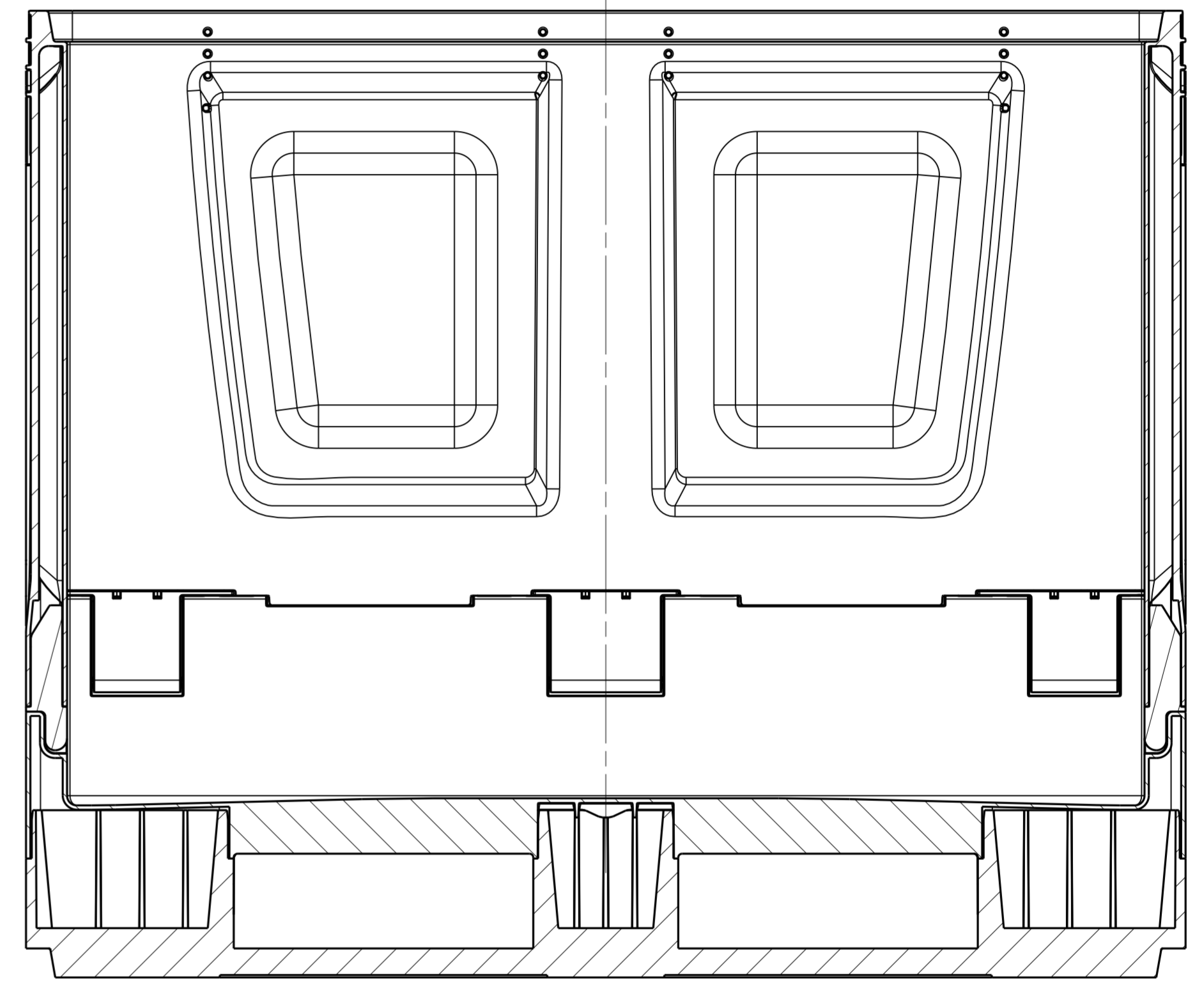

Füllvolumen= 900L

Zust.		Änderung		Datum		Name		Zu Verarb.Mech.		Gewicht:																													
30	1	1	1	1	1	1	1	Schwend. %	Schwendp.	rs																													
<table border="1"> <thead> <tr> <th>Gezeichnet</th> <th>Revisiert</th> <th>Datum</th> </tr> </thead> <tbody> <tr> <td></td> <td></td> <td>28.07.2011</td> </tr> </tbody> </table>								Gezeichnet	Revisiert	Datum			28.07.2011	<table border="1"> <thead> <tr> <th>Projektor</th> <th>Benennung</th> </tr> </thead> <tbody> <tr> <td></td> <td>KLK 1210K</td> </tr> </tbody> </table>		Projektor	Benennung		KLK 1210K	<table border="1"> <thead> <tr> <th>Auftrags-Nr.</th> <th>Teil-Nr.</th> </tr> </thead> <tbody> <tr> <td></td> <td></td> </tr> </tbody> </table>		Auftrags-Nr.	Teil-Nr.																
Gezeichnet	Revisiert	Datum																																					
		28.07.2011																																					
Projektor	Benennung																																						
	KLK 1210K																																						
Auftrags-Nr.	Teil-Nr.																																						
<table border="1"> <thead> <tr> <th>Mess</th> <th>Über</th> <th>Toleranz</th> <th>Messst.</th> </tr> </thead> <tbody> <tr> <td>30.0</td> <td>± 0.1</td> <td></td> <td>1:5</td> </tr> <tr> <td>30.00</td> <td>± 0.01</td> <td></td> <td></td> </tr> <tr> <td>30.000</td> <td>± 0.005</td> <td></td> <td></td> </tr> </tbody> </table>								Mess	Über	Toleranz	Messst.	30.0	± 0.1		1:5	30.00	± 0.01			30.000	± 0.005			<table border="1"> <thead> <tr> <th>Wkzgn.</th> <th>Wkzgn.</th> <th>Wkzgn.</th> <th>Wkzgn.</th> </tr> </thead> <tbody> <tr> <td></td> <td></td> <td></td> <td></td> </tr> </tbody> </table>		Wkzgn.	Wkzgn.	Wkzgn.	Wkzgn.					<table border="1"> <thead> <tr> <th>Blättnr.</th> <th>Blättnr.</th> </tr> </thead> <tbody> <tr> <td></td> <td></td> </tr> </tbody> </table>		Blättnr.	Blättnr.		
Mess	Über	Toleranz	Messst.																																				
30.0	± 0.1		1:5																																				
30.00	± 0.01																																						
30.000	± 0.005																																						
Wkzgn.	Wkzgn.	Wkzgn.	Wkzgn.																																				
Blättnr.	Blättnr.																																						
<table border="1"> <thead> <tr> <th>TeilPos.Nr.</th> <th>Produkt</th> </tr> </thead> <tbody> <tr> <td></td> <td>KLK 1210K</td> </tr> </tbody> </table>								TeilPos.Nr.	Produkt		KLK 1210K	<table border="1"> <thead> <tr> <th>Größe</th> <th>A</th> </tr> </thead> <tbody> <tr> <td></td> <td></td> </tr> </tbody> </table>		Größe	A																								
TeilPos.Nr.	Produkt																																						
	KLK 1210K																																						
Größe	A																																						